

684H-TM

preliminary product guide

features

- All new design
- 20 USt (18.1 t) rating
- 84 ft (25.6 m) compact six-section boom
- Full, mid-, and retracted span outriggers
- NEW Mentor LMI system
- Internal anti-two block
- Your choice of 3-axle chassis

contents

Features	2
Mounting Configurations	3
Specifications	4
Capacities	5
Dimensions Specifications	7
Accessories	8



features

Why Buy a National Crane 684H-TM Tractor Mount:

2



*Product may be shown with optional equipment.

- **20 USt (18.1 t) Rating** – The new 684H-TM provides a 20 USt (18.1 t) capacity.
- **84 ft (25.6 m) Six-section Boom** – The longest in its size range. The longer, compact boom allows the operator to perform more lifts without the use of a jib, reducing setup time and improving efficiency.
- **Overload Protection** – All National Crane boom trucks are equipped with overload protection:
 - Mentor Load Moment Indicator (LMI) is standard on all series 600H machines with (WADS) “work area definition system.”
 - LMI display console is weatherproof.
 - All crane load lifting values are displayed simultaneously.
- **Easy Glide Boom Wear Pads** – Reduce the conditions that cause boom chatter and vibration. The net result is smoother crane operation.
- **“HO”-style Outriggers** – One set of “HO”-style outriggers with 20 ft (6.09 m) span, with 8 ft (2.43 m) mid span setting with manual locks and reduced capacity chart, and fully retracted outrigger spread with reduced capacity chart.
Main outriggers are equipped with removable ball and socket aluminum foot pads.
- **Rotation** – The 684H-TM is standard with 375° non-continuous rotation.
- **Adjustable Swing Speed** – Standard on the 684H-TM. A control knob located on the swing motor brake release valve can be easily adjusted to the crane operator’s swing speed preference.
- **Speedy-reeve Boom Tip and Sheave Blocks** – These standard features simplify rigging changes by decreasing the time needed to change line reeving.
- **Burst-of-Speed Winch** – Provides faster winch payout and pickup of unloaded cable.
- **Gear Pump** – Three-section direct mount gear pump.
- **Shutoff valve on suction line for ease of maintenance.**
- **Pre-painted Components** – Painting crane components before assembly reduces the possibility of rust, improves serviceability and enhances the appearance of the machine.
- **Improved Serviceability** –
 - Bearings on the boom extend and retract cables can be greased through access holes in the boom side plates.
 - Number of boom parts has been reduced, decreasing service time when rebuilding the machine.
 - Internal anti-two-block wire routing eliminates damage potential.
- **Electronic versions of manuals available through Manitowoc Crane CARE.**
- **New State-of-the-art Control Valve** – Provides smoother operation. The new design eliminates parts, reducing repair costs and improving the machine’s serviceability.
- **National Crane is the Market Leader** – National Crane is number one in the production of commercial truck-mounted boom trucks and has many programs and people directly and indirectly involved to provide our customers reliable products.
 - National Crane has the boom truck industry’s leading test program. Every structural part of the crane is cycle tested up to 60,000 cycles at full capacity. In addition to cycle testing, each model is subjected to state-of-the-art strain gauge testing that measures metal deformation as small as one one-millionth of an inch. The net result is that any weak areas are caught in test, not on job sites where costly downtime occurs.
 - Lift and telescoping cylinders are manufactured by National Crane, so that the seals, packing glands, and end plates are traced for accurate shipment of replacement parts.
 - Parts are available for all National Crane machines for the life of the crane.
 - National Crane has a formalized quality program and is ISO 9001 approved.
- **National Crane’s Quality Management System is ISO 9001:2000 Approved.**

- 20 USt (18.1 t) maximum capacity
- 94 ft (28.6 m) maximum vertical hydraulic reach*
- Load Moment Indicator system (LMI)
- Proportional boom extension
- High performance planetary winch
- Heavy-duty triple pump hydraulics
- * Maximum vertical reach is ground-level to boom tip height at maximum extension and angle with outriggers/stabilizers fully extended.

684H-TM

mounting configuration

The configurations are based on the Series 684H-TM with an 85% stability factor. The complete unit must be installed in accordance with factory requirements and a test performed to determine actual stability and counterweight requirements since individual truck chassis vary.

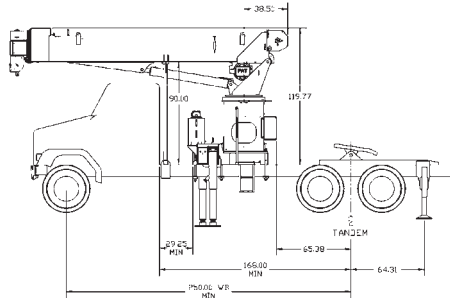

Configuration 1 with Torsion Box – 180° Full Capacity Work Area

Working area	180°
Gross Axle Weight Rating Front	20,000 lb (9072 kg)
Gross Axle Weight Rating Rear	34,000 lb (15,442 kg)
Gross Vehicle Weight Rating	54,000 lb (24,494 kg)
Wheelbase	250 in (635 cm)
Cab to Axle/trunnion (CA/CT)	168 in (427 cm)
Frame Section Modulus (SM) under crane:	
110,000 PSI (758 MPa)	30.0 in ³ (491.6 cm ³)
Frame Section Modulus (SM) over rear stabilizers:	
110,000 PSI (758 MPa)	30.0 in ³ (491.6 cm ³)
Stability Weight, Front	10,000 lb (4536 kg) minimum*
Stability Weight, Rear	9,500 lb (4309 kg) minimum*

3

This configuration is the least expensive method for the Model 684H-TM. This mount, with the crane mounted behind the cab, requires the least weight of all mounts for stability; thus, you can haul larger payloads on your truck. It requires standard subbase and rear (ASH) stabilizers.

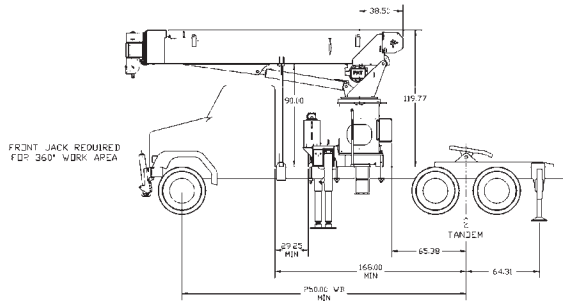

Configuration 2 with Torsion Box – 360° Full Capacity Work Area

Working area	360°
Gross Axle Weight Rating Front	20,000 lb (9072 kg)
Gross Axle Weight Rating Rear	34,000 lb (15,422 kg)
Gross Vehicle Weight Rating	54,000 lb (24,493 kg)
Wheelbase	250 in (635 cm)
Cab to Axle/trunnion (CA/CT)	168 in (427 cm)
Frame Section Modulus (SM) under crane:	
110,000 PSI (758 MPa)	30 in ³ (491.6 cm ³)
Frame Section Modulus (SM) over rear stabilizers:	
110,000 PSI (758 MPa)	30 in ³ (491.6 cm ³)
Stability Weight, Front	10,000 lb (4536 kg) minimum*
Stability Weight, Rear	9,500 lb (4309 kg) minimum*

Requires front SFO stabilizer to give machine full capacity 360° around the truck. Truck must meet the minimum requirements above. Front stabilizer gives the machine a solid base, helping the operator control loads precisely. Extended front frame rails required for SFO installation.

Notes:

- Gross Vehicle Weight rating (GVWR) is dependent on all components of the vehicle (axles, tires, springs, frame, etc.) meeting manufacturers' recommendations: always specify GVWR when purchasing trucks
- Diesel engines require a variable speed governor and energize-to-run fuel solenoid for smooth crane operation; electronic fuel injection requires EET engine remote throttle
- All mounting data is based on a National Series 684H-TM with an 85 percent stability factor

- The complete unit must be installed in accordance with factory requirements, and a test performed to determine actual stability and counterweight requirements per SAE J765; contact the factory for details
- Transmission neutral safety interlock switch is required with optional remote control

*Estimated axle scale rates prior to installation of crane, stabilizers and subbase for 85% stability.

684H-TM

specifications

Boom and Jib Combination Data

4 Model 684H TM – Equipped with a 19-84 ft (7.32-24.38 m) six-section boom. Max tip height is 94ft (28.6m).



Note: Maximum tip is measured with outriggers/stabilizers fully extended.

600H-TM Winch Data

600H-TM Winch Data

- All winch pulls and speeds in this chart are shown on the fourth layer
- Winch line pulls would increase on the first and second layers
- Winch line pulls may be limited by the winch capacity or the ANSI 5 to 1 cable safety factor, shown below this chart
- Hook blocks are rated at maximum capacity for the block. **Do not exceed rated cable pull with any block.**

600H-TM Winch Data			1 Part Line	2 Part Line	3 Part Line	4 Part Line	5 Part Line	6 Part Line
Winch	Cable Supplied	Average Breaking Strength	Max. Pull	Max. Pull	Max. Pull	Max. Pull	Max. Pull	Max. Pull
Standard Planetary Winch	9/16 in Diameter Rotation Resistant	38,500 lb (17,463 kg)	7,700 lb (3 492.66 kg)	15,400 lb (6 985.32 kg)	23,100 lb (10 477.98 kg)	30,800 lb (13 970.65 kg)	38,500 lb (14 514.96 kg)	40,000 lb (14 514.96 kg)

Layer	Winch Pull		Winch Speed		BOS Winch Speed		Rope Capacity	
	lb	(kg)	fpm	(mpm)	fpm	(mpm)	ft	(m)
1	10,380	(4708)	157	(48)	222	(68)	64	19
2	9,360	(4246)	175	(53)	246	(75)	136	41
3	8,520	(3865)	192	(59)	271	(83)	215	65
4	7,820	(3547)	209	(64)	294	(90)	301	91
5	7,230	(3279)	257	(69)	318	(97)	394	120

NOTE: All ratings based on 34 GPM at 3300 psi (128.7 LPM at 22.75 MPa)
Burst of Speed maximum pull = 3000 lb (1361 kg)

Winch	Bare Drum Pull	Allowable Cable Pull
With standard rotation resistant rope	10,200 lb (4627 kg)	7,700 lb (3493 kg)

Block Type	Rating	Weight
Downhaul Weight	3.85 USt (3.49 t)	150 lb (68 kg)
1 Sheave Block	11.55 USt (10.48 t)	200 lb (91 kg)
2 Sheave Block	19.25 USt (17.46 t)	355 lb (161 kg)

684H-TM

capacities

5

Load Rating Chart: Model 684H-TM (25.6 m) Boom/Fullspan Outrigger 20 ft (6.1 m) & Stabilizer

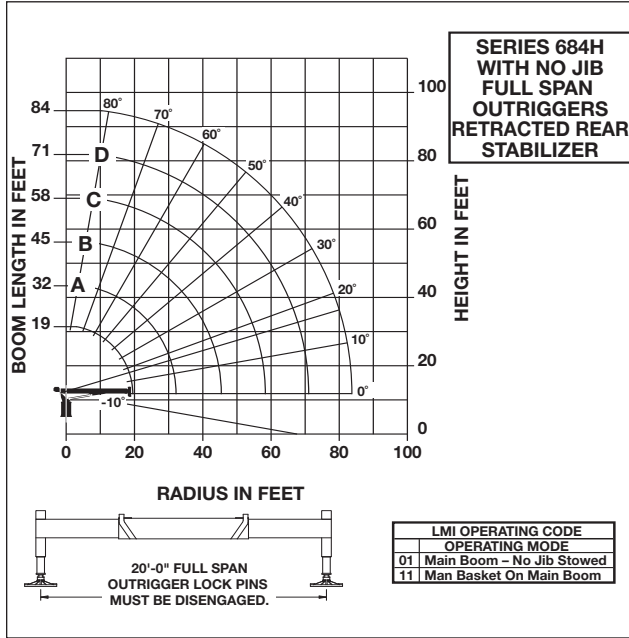

CAUTION:

- Do not operate crane booms, jib extensions, any accessories or loads within 10 ft (3m) of live power lines or other conductors of electricity.
- Boom capacities shown are maximum for each section.
- Do not exceed capacities at reduced radii.
- Load ratings shown on the appropriate charts are maximum allowable loads with the crane mounted on a factory-approved truck and all outriggers at full span range and set on a firm level surface so that the crane is level and all tires are suspended.
- Always level the crane with the level indicator located on the crane.
- The operator must reduce load to allow for factors such as wind, ground conditions, operating speeds and their effects on freely suspended loads.
- Overloading this crane may cause structural collapse or instability.
- Weights on any accessories attached to the boom or loadline must be deducted from the load chart capacities.
- Do not deadhead lineblock against boom tip when extending boom or winching up.
- Keep at least three wraps of loadline on drum at all times.
- Use only specified cable with this machine.

SERIES 684H-TM (25.6 M) BOOM/ FULLSPAN OUTRIGGER & STABILIZER

LOADLINE EQUIPMENT DEDUCT.

- Downhaul weight150 lb (68 kg)
- One sheave block200 lb (90.7 kg)
- Two sheave block.....355 lb (161 kg)

Load Rating Chart: Series 684H (25.6 m) Boom/Fullspan Outrigger 20 ft (6.1 m) & Stabilizer

LOADED RADIUS (ft)	LOADED BOOM ANGLE (deg)	19 FT BOOM (lb)	LOADED BOOM ANGLE (deg)	A 32 FT BOOM (lb)	LOADED BOOM ANGLE (deg)	B 45 FT BOOM (lb)	LOADED BOOM ANGLE (deg)	C 58 FT BOOM (lb)	LOADED BOOM ANGLE (deg)	D 71 FT BOOM (lb)	LOADED BOOM ANGLE (deg)	84 FT BOOM (lb)
6	71.7	40,000										
8	61.2	30,300	74	20,900	79.4	20,300						
10	53.5	25,500	70.5	20,650	76.8	17,600						
12	44.8	21,800	66.4	19,150	74.1	15,750	78.1	12,200				
14	34.9	18,550	62.2	17,400	71.4	14,450	76.1	11,250	79	8,700		
16	20.9	14,800	57.9	15,900	68.7	13,550	74.1	10,500	77.4	8,200	79.5	4,200
20			48.4	12,950	63	12,250	69.9	9,100	74.5	7,300	76.9	4,200
25			33.8	9,950	55.3	9,900	64.5	7,900	70.3	6,400	73.6	4,200
30					46.7	8,150	59.3	6,850	66	5,700	70.3	4,200
35					37.4	6,750	53.2	5,900	61.4	5,150	66.7	3,850
40					23.7	5,150	46.5	4,950	56.6	4,500	62.9	3,350
45							38.7	4,550	51.5	3,850	58.9	2,950
50							29	3,900	45.9	3,250	54.7	2,550
55									39.6	2,700	50.2	2,150
60									32.1	2,350	45.5	1,900
65									22.1	2,000	40.2	1,600
70											34.2	1,350
75											27	1,200
80											16.6	850
	0	8,300	0	3,900	0	2,100	0	1,050	0	500	0	150

*SHADED AREAS ARE STRUCTURALLY LIMITED CAPACITIES

684H-TM

THIS CHART IS ONLY A GUIDE AND SHOULD NOT BE USED TO OPERATE THE CRANE. The individual crane's load chart, operating instructions and other instructional plates must be read and understood prior to operating the crane.

capacities

6

Load Rating Chart: Series 684H-TM (27.4 m) Boom/Midspan Outrigger 13.3 ft (4.1 m) & Stabilizer

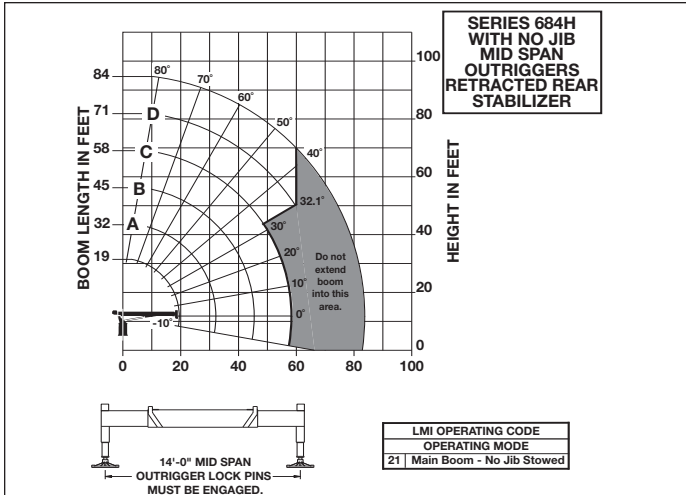

CAUTION:

- Do not operate crane booms, jib extensions, any accessories or loads within 10 ft (3m) of live power lines or other conductors of electricity.
- Boom capacities shown are maximum for each section.
- Do not exceed capacities at reduced radii.
- Load ratings shown on the appropriate charts are maximum allowable loads with the crane mounted on a factory-approved truck and all outriggers at either full span or at mid span range and set on a firm level surface so that the crane is level and all tires are suspended.
- Always level the crane with the level indicator located on the crane.
- The operator must reduce load to allow for factors such as wind, ground conditions, operating speeds and their effects on freely suspended loads.
- Overloading this crane may cause structural collapse or instability.
- Weights on any accessories attached to the boom or loadline must be deducted from the load chart capacities.
- Do not deadhead lineblock against boom tip when extending boom or winching up.
- Keep at least three wraps of loadline on drum at all times.
- Use only specified cable with this machine.

SERIES 684H-TM (27.4 M) BOOM/MIDSPAN OUTRIGGER & STABILIZER

LOADLINE EQUIPMENT DEDUCT

Downhaul weight.....150 lb (68 kg)
One sheave block200 lb (90.7 kg)
Two sheave block.....355 lb (161 kg)

Load Rating Chart: Series 684H-TM (27.4 m) Boom/ Midspan Outrigger 13.3 ft (4.1 m) & Stabilizer

LOADED RADIUS (ft)	LOADED BOOM ANGLE (deg)	19 FT BOOM (lb)	LOADED BOOM ANGLE (deg)	32 FT BOOM (lb)	LOADED BOOM ANGLE (deg)	45 FT BOOM (lb)	LOADED BOOM ANGLE (deg)	58 FT BOOM (lb)	LOADED BOOM ANGLE (deg)	71 FT BOOM (lb)	LOADED BOOM ANGLE (deg)	84 FT BOOM (lb)
6	71.7	40,000										
8	61.2	30,300	74	20,900	79.4	20,300						
10	53.5	25,500	70.5	20,650	76.8	17,600						
12	44.8	21,800	66.4	19,150	74.1	15,750	78.1	12,200				
14	34.9	18,550	62.2	17,400	71.4	14,450	76.1	11,250	79	8,700		
16	20.9	14,800	57.9	15,900	68.7	13,550	74.1	10,500	77.4	8,200	79.5	4,200
20			48.4	10,150	63	10,250	69.9	9,100	74.5	7,300	76.9	4,200
25			33.8	6,800	55.3	6,900	64.5	7,900	70.3	6,400	73.6	4,200
30					46.7	4,800	59.3	4,900	66.0	5,700	70.3	4,200
35					37.4	3,600	53.2	3,700	61.4	3,800	66.7	3,950
40					23.7	2,850	46.5	2,850	56.6	2,950	62.9	3,450
45							38.7	2,200	51.5	2,300	58.9	2,350
50							29	1,700	45.9	1,800	54.7	1,800
55							13.5	1,300	39.6	1,350	50.2	1,400
60									32.1	950	45.5	1,000
	0	8,500	0	2,800	0	2,100	0	1,000				

*SHADED AREAS ARE STRUCTURALLY LIMITED CAPACITIES

THIS CHART IS ONLY A GUIDE AND SHOULD NOT BE USED TO OPERATE THE CRANE. The individual crane's load chart, operating instructions and other instructional plates must be read and understood prior to operating the crane.

684H-TM

dimensions specifications

7

ML-H489

G CENTER OF GRAVITY FROM CENTERLINE		
Series	DRY WEIGHT*	W/OIL WEIGHT*
684H-TM	12,030 lb [5,457 kg]	12,835 lb [5,822 kg]

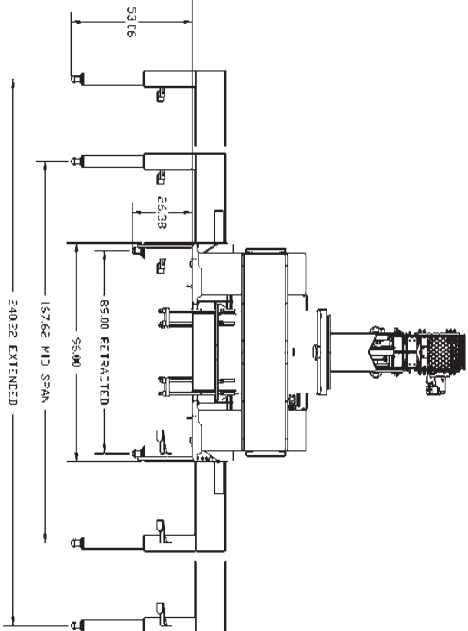
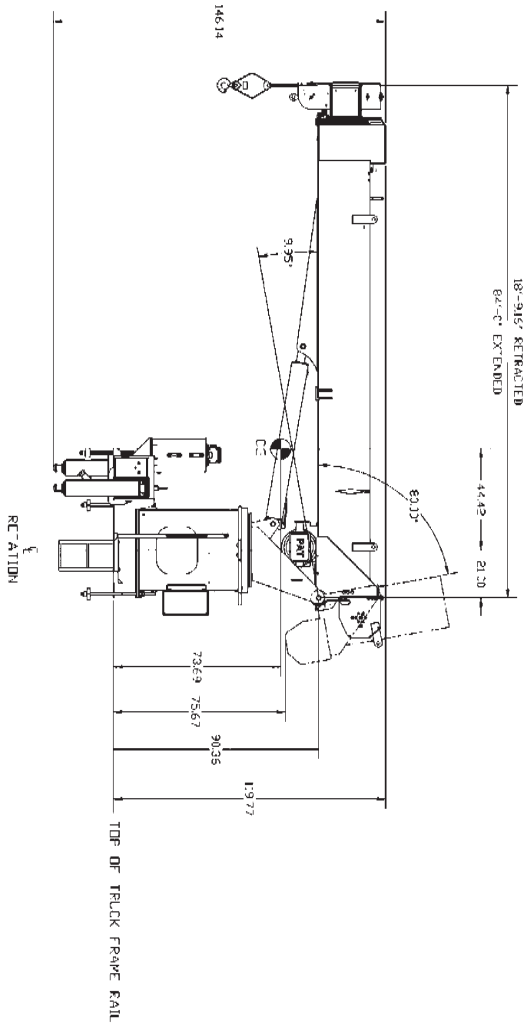
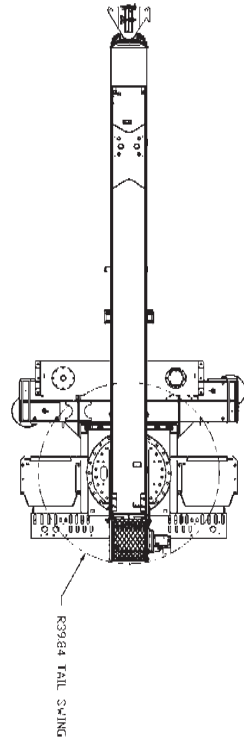

UNITS IN INCHES UNLESS SPECIFIED

* ABOVE WEIGHTS DO NOT INCLUDE RESERVOIR, RSOD, JIB, PTO, PUMP, BED
 ** WEIGHT INCLUDES BOOM, WINCH, ROPE, TURRET, LIFT CYLINDER, FRAME, CONTROLS, OUTRIGGERS, PLATFORMS, TORQUE BOX, BOOM REST, BUMPER, DOWNHAUL WEIGHT

accessories

8

Radio Remote Controls –

Eliminate the handling and maintenance concerns that accompany cabled remotes. Operate to a range of about 250 ft (76 m), varying with conditions.

• **RB4R**

One-Person Basket –

Strong but lightweight steel basket with 300 lb (139 kg) capacity, gravity hung with swing lock and full body harness.

• **B1-S**

• **2B1-S** (for dual locking baskets)

Heavy-duty Personnel Basket –

1,200 lb (544 kg) capacity steel basket with safety loops for four passengers. Gravity leveling 72 x 42 inch (183 x 107 cm) platform. Fast attachment and secure locking systems. Load chart must show 2,300 lb (1043 kg) minimum to operate this accessory.

• **BSA-1**

• **BSA-R1** (provides rotation)

Hydraulic Oil Cooler –

Automatic, self-contained radiator system with electric fans cools oil under continuous operation.

• **OC**

Hourmeter

In truck cab to record crane operation hours

• **HRM**

Outrigger Motion Alarm

For HO O/R and RSOD stabilizers

• **OMA-2**

Metric Capacity Charts

• **MCC**

Single Front Outrigger

Center front stabilizer with a 25 in vertical stroke

• **SFO**

Steel Tool Box Options

**Spanish-Language Danger Decals,
Control Knobs, and Operators' Manuals**

• **SDD**

• **SOM**

684H-TM

notes

10

684H-TM

Regional Headquarters
Americas

Manitowoc, Wisconsin, USA

Tel: +1 920 684 6621

Fax: +1 920 683 6278

Shady Grove, Pennsylvania, USA

Tel: +1 717 597 8121

Fax: +1 717 597 4062

Regional Offices
Americas
Brazil

Alphaville

Tel: +55 11 4688 2716

Fax: +55 11 4191 1471

Mexico

Monterrey

Tel: +52 81 8124 0128

Fax: +52 81 8124 0129

Europe, Middle East, Africa
Algeria

Hydra

Tel: +21 3 21 48 1173

Fax: +21 3 21 48 1454

Czech Republic

Netvorice

Tel: +420 317 78 9313

Fax: +420 317 78 9314

France

Baudemont

Tel: +33 385 28 2589

Fax: +33 385 28 0430

Cergy

Tel: +33 130 31 3150

Fax: +33 130 38 6085

Decines

Tel: +33 472 81 5000

Fax: +33 472 81 5010

Germany

Langenfeld

Tel: +49 21 73 8909-0

Fax: +49 21 73 8909 30

Hungary

Budapest

Tel: +36 13 39 8622

Fax: +36 13 39 8622

Italy

Parabiago

Tel: +390 331 49 3311

Fax: +390 331 49 3330

Europe, Middle East, Africa

Ecully, France

Tel: +33 472 18 2020

Fax: +33 472 18 2000

Netherlands

Breda

Tel: +31 76 578 3999

Fax: +31 76 578 3978

Poland

Warsaw

Tel: +48 22 843 3824

Fax: +48 22 843 3471

Portugal

Alfena

Tel: +351 229 69 8840

Fax: +351 229 69 8848

Lisbon

Tel: +351 212 109 340

Fax: +351 212 109 349

Russia

Moscow

Tel: +7 495 641 2359

Fax: +7 495 641 2358

U.A.E.

Dubai

Tel: +971 4 3381 861

Fax: +971 4 3382 343

U. K.

Middlesex

Tel: +44 1 895 43 0053

Fax: +44 1 895 45 9500

Sunderland

Tel: +44 191 522 2000

Fax: +44 191 522 2052

Asia – Pacific
Australia

Melbourne

Tel: +61 3 9 336 1300

Fax: +61 3 9 336 1322

Sydney

Tel: +61 2 9 896 4433

Fax: +61 2 9 896 3122

Asia – Pacific

Shanghai, China

Tel: +86 21 51113579

Fax: +86 21 51113578

Singapore

Tel: +65 6264 1188

Fax: +65 6862 4142

China

Beijing

Tel: +86 10 58674761

Fax: +86 10 58674760

Xi'an

Tel: +86 29 87891465

Fax: +86 29 87884504

Korea

Seoul

Tel: +82 2 3439 0400

Fax: +82 2 3439 0405

Philippines

Makati City

Tel: +63 2 844 9437

Fax: +63 2 844 4712

Factories

Brazil

Alphaville

China

Zhangjiagang

France

Charlieu

La Clayette

Moulins

Germany

Wilhelmshaven

India

Calcutta

Pune

Italy

Niella Tanaro

Portugal

Fânzeres

U.S.A.

Manitowoc

Port Washington

Shady Grove

Constant improvement and engineering progress make it necessary that we reserve the right to make specification, equipment and price changes without notice. Illustrations shown may include optional equipment and accessories, and may not include all standard equipment.